

Wind Energy Lab Module for Mechanical Engineering Undergraduate Curricula*

EVERETT SHEBLE, STEFFEN BICKLE and CARLOS H. HIDROVO

Mechanical Engineering Department, The University of Texas at Austin, Austin, Texas, USA. E-mail: hidrovo@mail.utexas.edu

This paper describes the development and implementation of a project-oriented undergraduate-level fluid mechanics laboratory experiment centered on evaluating the performance of a scale-model wind turbine. It seeks to provide a road map for educators who wish to use the material within their engineering curricula, and to demonstrate that material's effectiveness. Technical concepts explored include power and energy, wind turbine theory and practice, dimensional analysis, scientific uncertainty and engineering measurement. Instructions for assembling the laboratory set-up are included, along with examples of results obtained by undergraduate students performing the experiment at the Mechanical Engineering Department of The University of Texas at Austin in the Spring 2013 semester. Students' proficiency was measured via pre- and post-project examination. Students were also invited to complete a survey to provide feedback on their experience of completing the lab. Results of the examinations and surveys were mostly positive, with excellent improvement in a broad range of tested competencies and high levels of student satisfaction. Methods for addressing the areas that need improvement are discussed, in particular the content on dimensional analysis and scientific uncertainty.

Keywords: wind energy; fluid mechanics; efficiency; power coefficient; wind turbine

1. Introduction

In recent years, wind power has become the fastest-growing electricity source in the U.S. [1]. This growth, along with tax credits and other incentives, has created substantial opportunities for prepared engineers and scientists. Adaptation of educational curricula to the market's status quo is crucial for university engineering programs to remain relevant, and this is especially true of the innovative energy sector.

Project-oriented, industry-related coursework has facilitated this adaptation at The University of Texas at Austin's Mechanical Engineering Department in the form of PROCEED (Project-Centered Education). PROCEED is a curriculum reform effort with the following primary objectives:

- (1) to strengthen . . . students' understanding of fundamental engineering theory by continuously tying it to tangible objects and systems; (2) to strengthen [the] Department's connections with its industrial stakeholders by actively involving them in the development and delivery of curriculum content; (3) to provide . . . students with a broad range of team-based experiences which will better prepare them for growth and leadership in the corporate and professional world. [2]

In accordance with the principles of PROCEED and the state of the industry, a new fluid mechanics laboratory experiment has been developed around wind turbine performance measurement and evaluation. This serves to introduce students to industry standards and practices, to increase their

understanding of fluid mechanics theory by integrating it into a practical engineering problem, and to develop group organizational and operational skills in a project-oriented environment.

Although the curriculum developed in this paper uses PROCEED's pedagogical approaches, it does not seek to directly evaluate its merits. In fact, this paper is not meant to explore educational theory; rather it seeks to provide technical content for science and engineering educators within an established teaching framework. There is some limited feedback on the value of PROCEED in the context of wind energy, fluid mechanics and the lab module, but the focus is essentially on the blueprint for creating a similar module, alongside the learning objectives and how well they were reached. That being said, the authors feel that the material presented below can be easily scaled for different levels of complexity and/or weighted toward different learning objectives depending on the goals of the implementer.

2. Background

Installed wind capacity in the U.S. has been growing by 30–60% per year [1], and currently the top ten wind-producing states provide 42 000–52 000 jobs in the wind energy sector [3]. Projections put the number of nation-wide wind power jobs at 100 000 by 2015 and 500 000 by 2030 [3].

Wind turbines extract kinetic energy from the wind (in the form of air in motion), converting it into rotational mechanical energy, which is then used

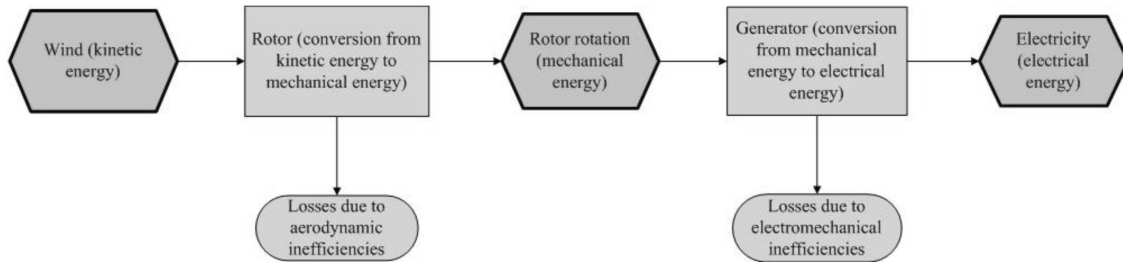

Fig. 1. Power flows and losses. A power flow diagram summarizes the important elements of a wind turbine system. Kinetic energy in the motion of the wind is converted to mechanical energy of a spinning rotor via the turbine blades, with some losses due to aerodynamic inefficiency. That mechanical energy is converted to electrical energy via an electrical generator, with additional losses due to electromechanical inefficiency.

to drive a generator to produce electricity. Losses occur at each conversion step, as shown in Fig. 1.

The electromechanical efficiency characterizes losses that occur due to things like bearing friction and resistive losses in wiring. Electromechanical efficiencies of full-size wind turbines are typically very high, and get higher as turbines are scaled up. This is one reason for the trend of larger turbines over time [6]. The aerodynamic efficiency, commonly called the power coefficient (C_p), characterizes how well the rotor extracts power from the wind (i.e. what fraction of the wind's power is converted to mechanical energy). The product of the power coefficient and the electromechanical efficiency is the overall efficiency of the device.

$$\eta_{overall} = C_p \eta_{em} \quad (1)$$

In 1919, German physicist Albert Betz determined that C_p could never be greater than approximately 0.593. In other words, even the best-designed turbine could only hope to capture 59.3% of the power in the wind. This is because there must be some fluid rejected in order to maintain a velocity gradient. If, for instance, the turbine extracted all of the energy from the initially moving air, it would then have zero velocity and stagnate just behind the turbine [4].

The three efficiencies described above are ratios of the various power inputs and outputs shown in Fig. 1. These ratios, along with other quantities such as the tip-speed ratio (defined by Equation 8), are non-dimensional parameters, i.e. they no longer depend on the scale of the system in question. These parameters are the key to comparing scale models with their full-scale counterparts, allowing for drastically reduced costs of experimentation and, in some cases, enabling experimentation that would have otherwise been impossible. In the case of wind turbines, it is specifically useful to compare the power coefficients and the tip-speed ratios of scale-model and full-scale cases. Figure 2 shows a common plot of these two parameters, with the

power coefficient as a function of the tip-speed ratio. The scale model to be evaluated in this laboratory should display similar trends to those found in Fig. 2.

The first part of establishing the aforementioned parameters is to quantify the power inputs and outputs shown in Fig. 1. The power in the wind is given by

$$P_{wind} = \frac{1}{2} \rho A U_{\infty}^3 \quad (2)$$

where ρ is the fluid density (in this case, that of air), A is the area swept out by the blades (and thus excludes the rotor hub), and U_{∞} is the velocity of the fluid.

The rotational mechanical power coming from the rotor is given by

$$P_{rotor} = T\omega = T \frac{2\pi N}{60} \quad (3)$$

where T is the torque on the rotor shaft, ω is the angular speed in radians/sec of the shaft, and N is the angular speed in RPM [6].

The electrical output power is measured over a load (impedance/resistance), and is given by

$$P_{elec} = \frac{V_{out}^2}{R} \quad (4)$$

where V_{out} is the voltage drop across the load and R is the load [7].

Now, the expressions for the efficiencies can be expanded into:

$$\eta_{overall} = \frac{P_{elec}}{P_{wind}} = \frac{\frac{V_{out}^2}{R}}{\frac{1}{2} \rho A U_{\infty}^3} \quad (5)$$

$$\eta_{em} = \frac{P_{elec}}{P_{rotor}} = \frac{\frac{V_{out}^2}{R}}{T\omega} \quad (6)$$

$$C_p = \frac{P_{rotor}}{\frac{1}{2} \rho A U_{\infty}^3} \quad (7)$$

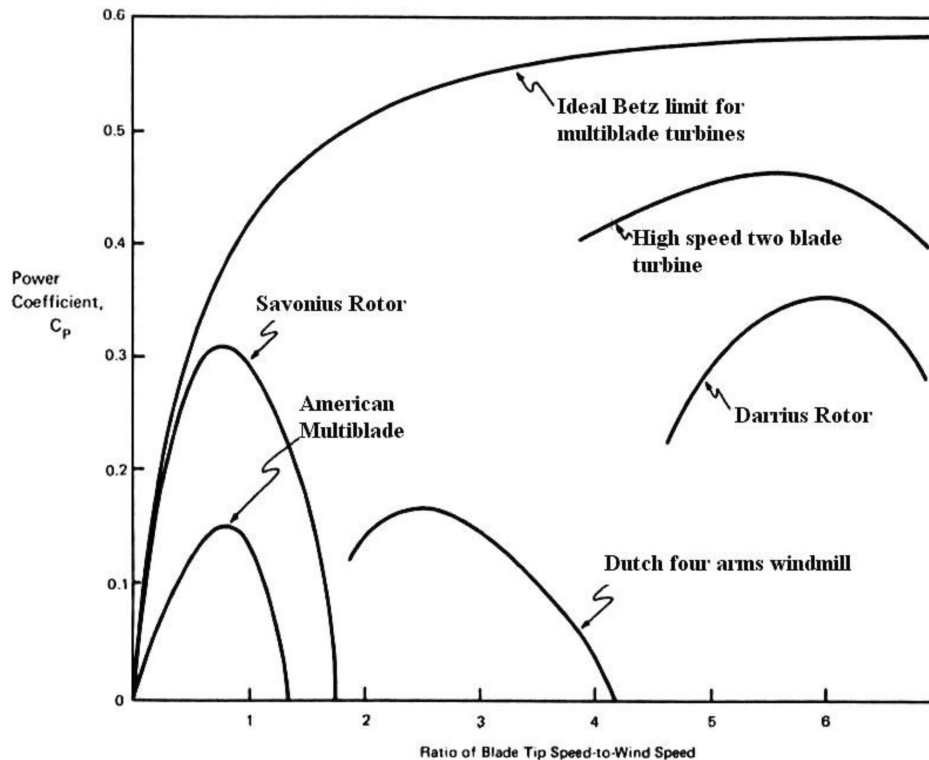

Fig. 2. Power coefficient for different wind turbines. Power coefficients for the most efficient designs of the various wind turbine types are shown in Fig. 2 (C_p is shown on the vertical axis while the tip-speed ratio is shown on the horizontal axis). The general Betz limit is the upper bound for the plot [5].

There is one other quantity of interest: the tip-speed ratio (TSR or λ). C_p has been shown to be a function of the tip-speed ratio [9, 10], a dimensionless parameter given by

$$\lambda = \frac{\omega r}{U_\infty} \quad (8)$$

where r is the radius of the rotor. Together, the tip-speed ratio and power coefficient capture the rotor performance characteristics, whether they are produced by geometric features or by ambient conditions. They allow dimensional analysis to be performed and two turbines of different shapes and sizes to be compared (e.g. in prototype design from scale models) [6].

During the implementation of the lab, students were allowed to change the angle of attack of the wind turbine blades to determine what effect this would have on the device's performance. This term, also called the pitch angle or blade pitch, is usually designated as β or θ . Decreasing the pitch angle generally results in higher peak aerodynamic efficiency, while increasing it can be used to decrease the angular speed of the turbine and prevent damage in high-speed winds. See Fig. 3.

One other expression is necessary for this experiment's measurement and computation, and that is Equation 9 used to estimate error propagation:

$$S_f = \sqrt{\left(\frac{\partial f}{\partial x}\right)^2 s_x^2 + \left(\frac{\partial f}{\partial y}\right)^2 s_y^2 + \left(\frac{\partial f}{\partial z}\right)^2 s_z^2 + \dots} \quad (9)$$

where S_f is the estimate of the uncertainty of the function $f(x, y, z, \dots)$, and $s_i, i = x, y, z, \dots$ is the estimate of the uncertainty of each variable (taken from the accuracy of each measured quantity in this context). The function f may be put in terms of only independent variables for this calculation [16]. In this way, errors in the measurement of quantities such as the voltage, the angular speed and the wind speed can be tracked through to the calculation of such desired parameters as C_p and λ .

3. Previous work

Several key components of this paper have been explored in other works. Colleagues in the Electrical Engineering Department at the University of Texas at Austin and the University of Texas, Pan American developed laboratory experiments exploring 'wind turbine technologies and wind power experiments for undergraduate-level engineering courses' [12]. These experiments consisted of two parts: a model-simulation section and a hardware-measurement section. Similarly to the approach used here,

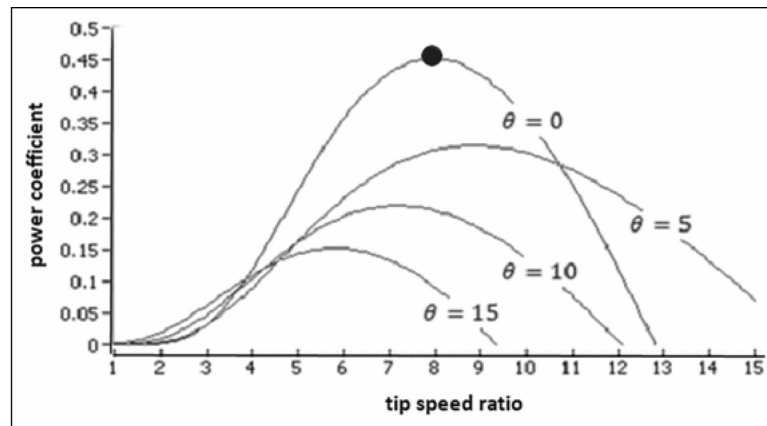

Fig. 3. Power coefficient vs. tip-speed ratio for various pitch angles (called θ here). Higher pitch angles mean that the blades cut into the wind like an airplane wing, whereas lower pitch angles mean the blades face flat against the wind [8].

the authors used a DC motor to specify the torque/power input to the turbine's generator. This allows for the isolation of the electromechanical and aerodynamic efficiencies, but in their case, the experiment's focus was very much on the electromechanical performance of various types of generators associated with wind energy capture (i.e. aerodynamic performance was assumed). In contrast, the emphasis of this paper's lab module was on wind energy in the context of fluid mechanics, so the majority of the focus is placed on aerodynamic behavior and performance. In other words, the isolation of parameters using the DC motor allows students to get at the essence of the fluid mechanics within wind turbine performance problems. An earlier paper from Carlos III University of Madrid also explores the use of a DC motor to run a wind turbine's generator as a way to enable wind turbine emulation in a laboratory environment. The authors intend for the set-up to be used to investigate the effects on power quality of 'the mean torque ... [and] the oscillating torque due to wind shear and tower shadow', and as an educational tool [13]. Likewise, though, that paper does not explore the aerodynamic side of the wind turbine's dual nature. Furthermore, neither of those papers presents pedagogical assessments of their work.

There are at least two previously published papers that use the context of wind energy to teach engineering concepts and provide pedagogical assessments of their curricula. The first, from California State University, Chico, details the set-up and implementation of two renewable-energy labs: a solar photovoltaic performance evaluation lab and a wind turbine performance evaluation lab. In the latter, the authors use a full-scale, 400 W turbine mounted outside (ambient conditions) and the turbine's performance is monitored over several days. The paper describes the lab as 'primarily a

data reduction exercise since the system operates automatically after it is turned on' [14]. This differs from the live, scale-model, controlled conditions under which this paper's experiments are run. Also, the paper does not isolate the aerodynamic and electromechanical efficiencies from each other. Finally, though the paper allows students to provide feedback via a survey on the effectiveness of the labs, it does not explore how well students assimilated and/or employed the knowledge and skills intended to be gained by doing them.

The second paper, published by two engineering teachers from the Andover Public School district in Massachusetts, details a project-based enhancement to middle school engineering curriculum based on the testing and redesign of model wind turbines. They find that 'project-based active learning is integral in a successful engineering education program,' albeit in a middle school environment [15]. Regardless, since project-centered education comprised the framework of both papers' pedagogical approaches, their assessments reaffirm the decision to orient this paper's undergraduate curriculum around PROCEED. In other words, the two papers are more difficult to compare, as the technical content of undergraduate labs is inevitably more in-depth. At the same time, there was overlap in the learning objectives of both, such as power and energy concepts and engineering measurement. Rather than laying out a plan for an individual lab module, though, the authors focus on the merits of project-based learning, with the wind turbine testing and redesign being just one realization of the active learning they espouse. Additionally, their examination of student performance is somewhat indirect, relying on state standardized tests as opposed to targeted, quantifiable testing. The authors do provide substantial qualitative evidence of students' improvement.

The authors of this paper opine that the singular application here of PROCEED to a wind turbine engineering lab in the context of fluid mechanics make it of unique value to educators in science and engineering. Other works lack the use of scale models in controlled environments that allow the exploration of dimensional analysis, an important tool in engineering and specifically in fluid mechanics. The separation of aerodynamic and electromechanical efficiency parameters (and the subsequent focus on variable changes' effects on those aerodynamic trends) is also particular. Lastly, this paper's extensive pedagogical assessments provide an excellent picture of how this curriculum positively impacted students. Even so, there is much merit in the works described above, and any reader interested in the content presented here would also benefit from perusal of these papers.

4. Set-up and procedure

The lab is divided into two stations: one utilizing the wind tunnel in order to obtain $\eta_{overall}$ and one utilizing a DC electric motor to obtain η_{em} . A list of tools and materials used in this version of the experiment for each station is provided, along with the experimental procedure. In addition to the following, examples of the lab documentation can be found at: www.me.utexas.edu/~hidrovo/papers/manual/Example%20Lab%20Preparation%20Guide%20and%20Manual.pdf.

For every measurement that students take, they also record the relevant accuracy of that measurement (given in the lab manual on a per device basis, e.g. the vane anemometer has an accuracy of $\pm(2\% + 0.2\frac{m}{s})$). In this way, students can track the propagation of uncertainty through their calcula-

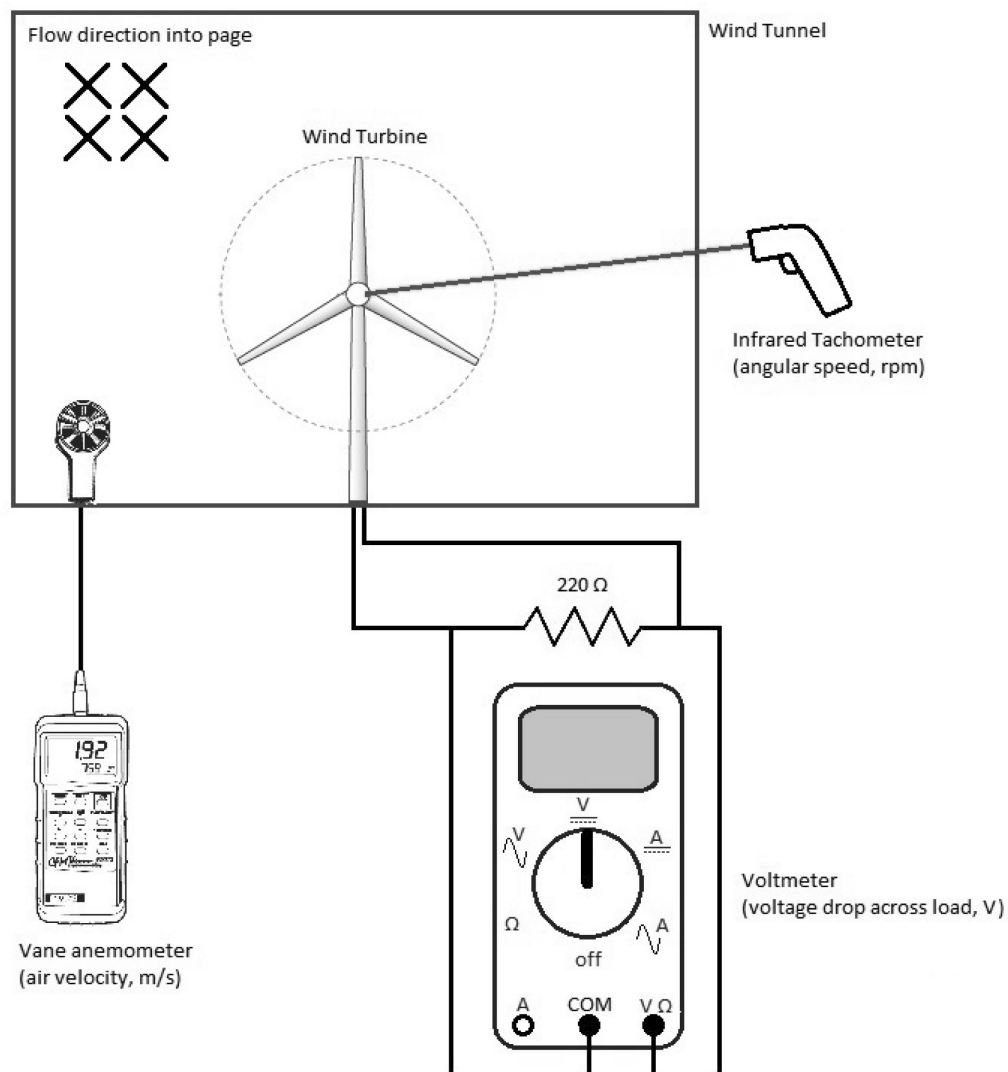

Fig. 4. Diagram of Station 1. A vane anemometer measures the wind speed directly. The infrared tachometer is used to measure the turbine angular speed via reflective tape on the rotor. Finally, the turbine is connected to a resistive load and a voltmeter is used to measure the voltage drop across that load.

tions of the desired quantities, namely C_p and the tip-speed ratio. See Equation 9 and its explanation for more information.

4.1 Overall efficiency characterization ($\eta_{overall}$) (Station 1)

Equipment:

- Wind tunnel (test section dimensions approximately 16×16 inches, capable range of velocities approximately 0–20 m/s)
- Extech 407113 CFM metal vane anemometer, heavy duty
- DT-2234C+ digital tachometer with reflective tape
- Horizon Fuel Cell Technologies WindPitch wind turbine
- Omega HHM16 Multimeter
- 220 Ω resistor (3–5 W power rating)

Not listed here are the materials needed to mount the wind turbine and vane anemometer inside the wind tunnel.

A diagram and photograph of Station 1 are shown in Figs 4 and 5, respectively.

In this station, students vary the air velocity by adjusting the wind tunnel motor speed. For each wind tunnel setting, they take measurements of the air velocity (using the vane anemometer), the angular speed (using the infrared tachometer, with reflective tape attached to the turbine rotor hub), and the voltage drop across the load resistance (using a voltmeter). Students may also measure the wind turbine rotor radius τ and the load resistance R , or they may be given these values. Using the equations detailed in the above section, they use this information to find the power in the wind (P_{wind}), the electrical output power (P_{elec}), and thus find the overall efficiency $\eta_{overall}$.

The wind turbine used in this experiment includes a generator connected to a rectifier bridge, and thus produces essentially DC power.

A summary of the procedure is presented below.

1. Vary the wind tunnel motor setting.
2. Allow 10 seconds for equilibration.
3. Record the air velocity.
4. Record the angular speed.
5. Record the voltage drop across the load.
6. Repeat until enough data has been obtained.

Interested students can be encouraged to repeat the above procedure after adjusting the angle of attack of the wind turbine blades. This wind turbine model allows for this function, so some groups can collect two data sets at different blade angle settings.

After the Station 1 procedure is completed, students switch to Station 2.

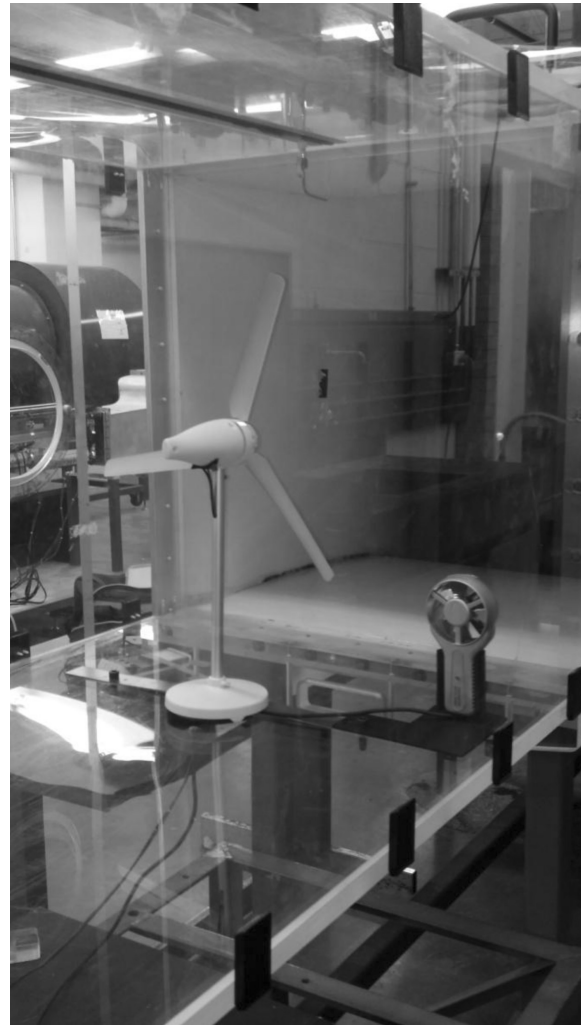

Fig. 5. Photograph of Station 1. A photograph of inside the wind tunnel test section is shown. The model wind turbine can be seen on the left and the vane anemometer can be seen on the right.

4.2 Electromechanical efficiency characterization (η_{em}) (Station 2)

Equipment:

- Mastech Hy1803d variable DC power supply
- Faulhaber Micromo 2237 006 CXR DC electric motor
- DT-2234C+ digital tachometer with reflective tape
- Generator from Horizon Fuel Cell Technologies WindPitch wind turbine (removed from device)
- Omega HHM16 multimeter
- 220 Ω resistor (3–5 W power rating)
- Ruland Manufacturing 4 beam clamp coupling (bore 3×3 mm)

Not listed here are the materials needed to mount/support the electric motor and generator.

A diagram and photograph of Station 2 are shown in Figs 6 and 7, respectively.

Just as students vary ‘input’ power via the wind

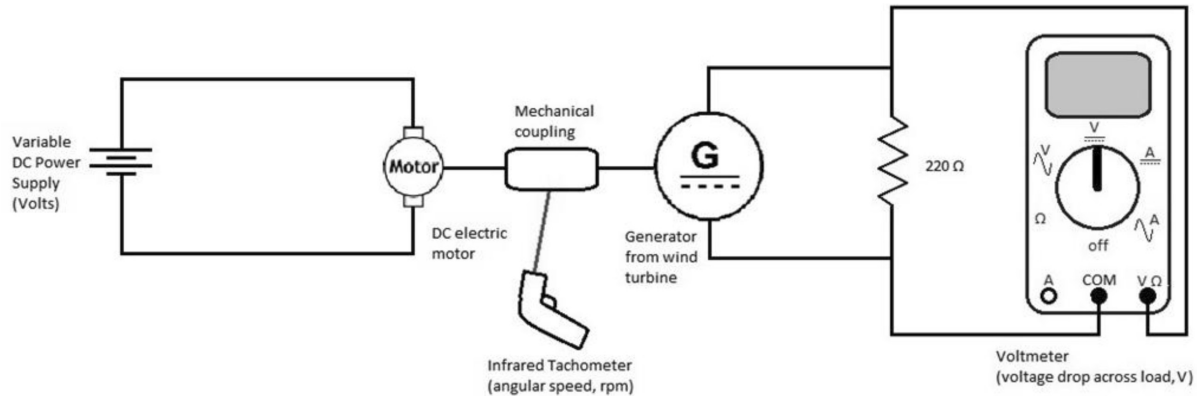

Fig. 6. Diagram of Station 2. A variable DC power supply runs a DC electric motor. The motor is coupled to the generator from the model wind turbine. The generator is connected to the same resistive load as in Station 1, and a voltmeter measures the voltage drop across the load. The infrared tachometer is used to measure angular speed with reflective tape placed on the mechanical coupling.

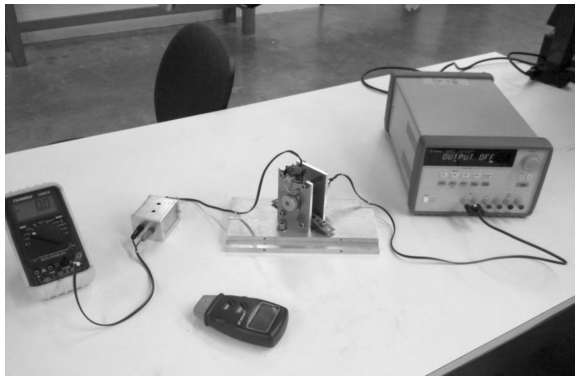

Fig. 7. Photograph of Station 2. From left to right are the voltmeter, resistor, tachometer, generator and DC motor, and the variable DC power supply.

tunnel setting in Station 1, they do so in Station 2 by varying the voltage applied to a DC electric motor (via a variable DC power supply) driving the turbine generator. The electric motor has well known characteristics (e.g. the angular speed with no load applied varies linearly with the voltage supplied to the motor, as described below). The characterization of the motor (performed by the manufacturer) allows the mechanical power reaching the generator to be calculated (P_{rotor}). As in Station 1, the infrared tachometer is used to measure shaft speed (using reflective tape affixed to the coupler) and a voltmeter is used to measure the voltage drop across the load (which must have the same value as the load in Station 1) and thus P_{elec} can be calculated. Students may then calculate η_{em} .

A summary of the procedure is presented below.

1. Vary and record the DC Power Supply setting.
2. Allow 10 seconds for equilibration.
3. Record the angular speed.
4. Record the voltage drop across the load.
5. Repeat until enough data has been obtained.

It is important to match the range of data obtained in Station 2 to that obtained in Station 1. In other words, students must calculate η_{em} for the same angular speeds that were measured in Station 1. This can be done either in series by recording the angular speed in Station 1 and reproducing it by changing the DC power supply setting until the same speed is obtained or by recording Station 2 data over the same range and curve fitting/interpolating. The latter was used in the implementation of this lab at UT Austin to allow two teams to alternate using the stations.

With both $\eta_{overall}$ and η_{em} now in hand, students may calculate C_p . They also have all the information necessary to calculate the tip-speed ratio, λ .

4.3 Characterization of the DC motor and generator

As described above, a DC electric motor is utilized during the lab to specify the torque input to the turbine generator, and so the equations describing its behavior are also necessary. The torque supplied by the motor can be calculated using constants provided by the motor manufacturer and the following:

$$T = \frac{\Delta T}{\Delta n} [k_n (V_{motor} - V_{offset}) - N] \quad (10)$$

where $\frac{\Delta T}{\Delta n}$ is the slope of the n - M curve (N - m /RPM), generally denoted as $\frac{\Delta M}{\Delta n}$ by industry. It describes how the motor's speed responds to changes in the load. k_n is the speed constant (RPM/V), which describes how the motor's no-load speed responds to changes in the voltage applied to the motor. V_{motor} is the voltage applied to the motor. V_{offset} is the minimum voltage that can be applied to the motor at no load before it begins to rotate. N is the measured angular speed of the motor shaft (RPM).

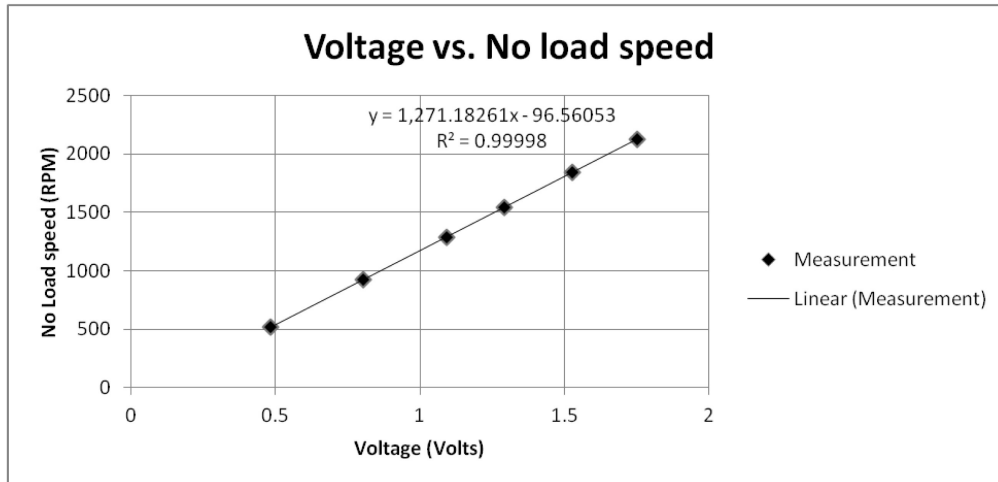

Fig. 8. DC motor characterization. Supplied voltage is shown on the horizontal axis and angular speed with no load applied to the motor shown on the vertical axis. A linear fit confirms the manufacturer’s specifications of k_n and provides V_{offset} .

The quantity $k_n(V_{motor} - V_{offset})$ is the no-load speed for the applied voltage [7, 11].

In this case, V_{offset} was not provided by the manufacturer and had to be determined experimentally by applying different voltages to the motor with no load, measuring the angular speed of the motor, and using a linear fit to find the intercept. This offset represents the voltage required to overcome internal, static friction and ‘start’ the motor. Figure 8 provides an example of this curve fit, where k_n is the slope and V_{offset} is the y -intercept.

Likewise, the generator within the wind turbine can be characterized by a linear relationship between voltage out (V_{out}) and angular speed (N). Once data from Station 2 has been collected, students establish this relationship via a linear curve fit. This equation (V_{out} as a function of N) is substituted into Equation 4 to obtain an expression of P_{elec} in terms of N . Finally, this expression is substituted into Equation 6, resulting in a formula describing n_{em} in terms of N . This result is plotted over the angular speed range from Station 1 (and compared

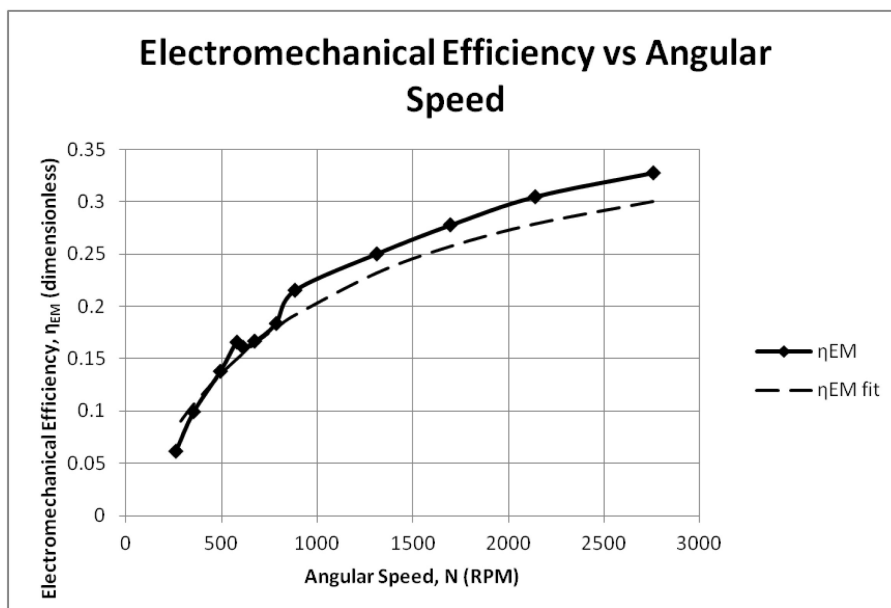

Fig. 9. Station 2 student results. Angular speed is shown on the horizontal axis and electromechanical efficiency on the vertical axis. Also shown is the curve fit that students used for interpolation to find efficiency values at specific angular speeds.

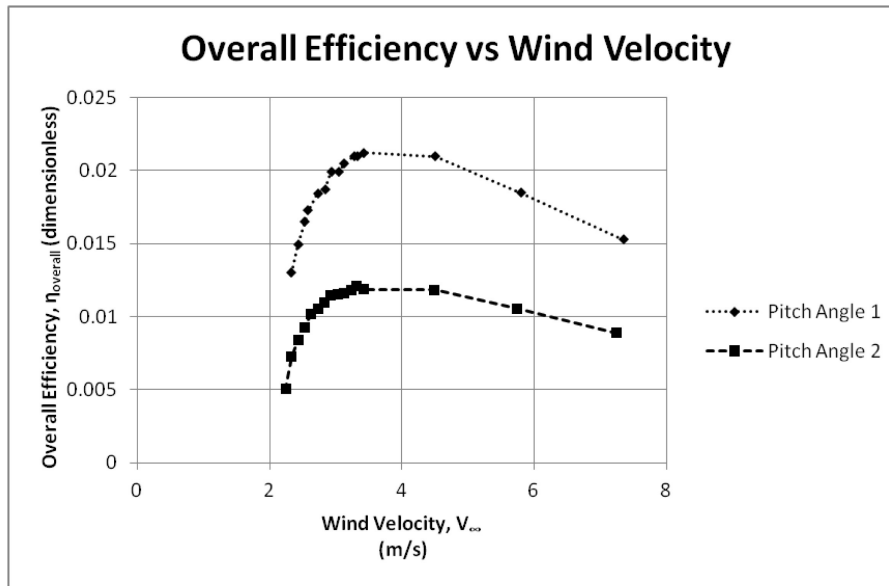

Fig. 10. Station 1 student results. Wind velocity is shown on the horizontal axis and overall efficiency on the vertical axis. Results are shown for two different pitch angles (Pitch Angle 1 < Pitch Angle 2).

with the empirical results obtained in Station 2) and is shown in Fig. 9.

5. Example of student results

A sample of student results is presented here. This student group performed the experiment as part of the core curriculum of their Mechanical Engineering degrees at UT Austin in the Spring of 2012. Figure 9 shows the results from Station 2—an empirical plot and fit of the electromechanical

efficiency versus angular speed of the wind turbine generator.

Next are the results obtained from Station 1—the overall efficiency versus wind speed, shown in Fig. 10.

Finally, using the above data and the theory presented earlier, the student group was able to determine the aerodynamic efficiency and tip-speed ratio. The results are shown in Fig. 11.

The trends compare favorably with those predicted by Figs 2 and 3 for full-size turbines. Power

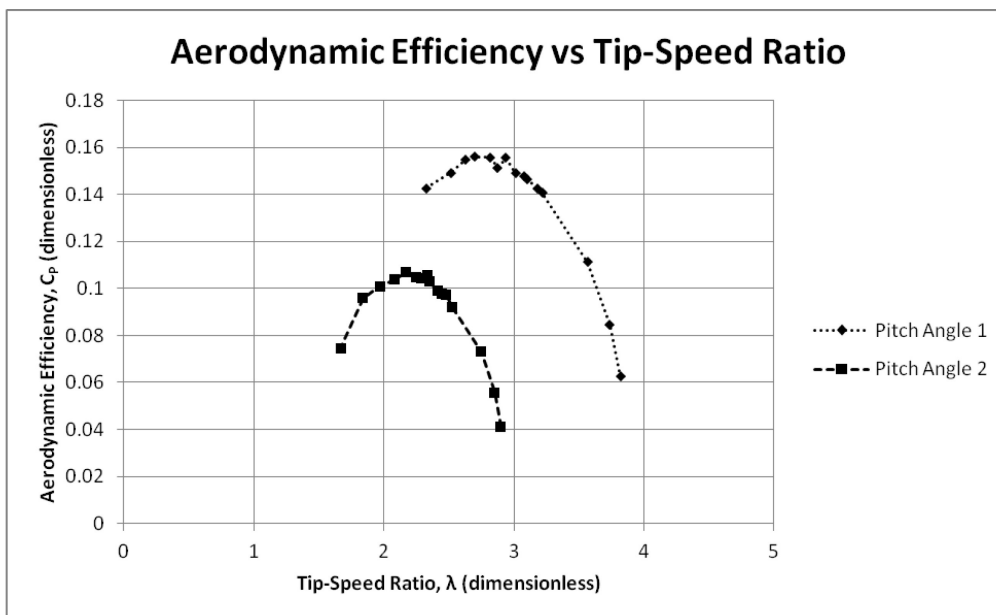

Fig. 11. Final student results. Aerodynamic efficiency is shown on the vertical axis and tip-speed ratio on the horizontal axis. Results for two different pitch angles are shown (Pitch Angle 1 < Pitch Angle 2).

Table 1. Pre- and post-lab results of student examinations. There were 138 graded pre- attempts and 120 graded post- attempts

	Pre % correct	Post % correct	Improvement/ Δ
Overall average	61.6%	84.6%	23.0%
Wind turbines/Fluid mechanics	52.3%	82.5%	30.2%
Scientific uncertainty	81.1%	85.5%	4.4%
Dimensional analysis	56.0%	93.0%	37.0%

coefficient trends show a vaguely parabolic shape, with peak C_p ranging from about 0.1 to 0.15. In the laboratory write-ups, students used this data to compare and contrast the performance of full-scale turbines, and draw conclusions about those differences and similarities. As the efficiency does not reach that expected for a modern HAWT, students were able to critique the model's design. Similarly, as the pitch angle was reduced, operational tip-speed ratio range shifted and peak C_p increased.

6. Assessments

This section consists of examinations of student competency in target areas both before and after having completed the lab experiment and student surveys to collect feedback on the perceived efficacy of the lab. For the former, students were given a 26-question multiple choice and true/false quiz that tested them on three main areas: Wind turbines/ Fluid mechanics (15), Scientific uncertainty (8), and Dimensional analysis (3). These quizzes were admi-

nistered online and data was assembled and organized so that student identities were excluded. As such, before vs. after performance was only tracked at the class level. The quiz used can be found in the Appendix. Results for the whole and the specific areas are summarized in Table 1.

Noticeable gains were made by the class as a whole. Analysis of these results on a question-by-question basis reveal that many students already had a good grasp of the lab module's material (i.e. the percentage of correct responses in the before quiz was greater than 70%), as with scientific uncertainty. This implies that the lab could be modified to include more advanced content on uncertainty analysis. Excluding those questions, overall average improvement was at 38.5%. Further analysis also revealed areas that still need attention (questions with less than 70% correct response in the after quiz), such as questions about power and wind velocity, blade pitch angle and aerodynamic efficiency, turbine types, and the estimation of uncertainty.

Students were invited to complete an optional survey after they had completed the Spring offering

Question	Strongly disagree					Strongly agree
	Disagree	Neutral	Agree			
1. My knowledge of wind turbine theory and practice has increased as a result of Lab #4.	0%	0%	1%	44%	54%	
2. My understanding of power, efficiency, and losses has improved as a result of Lab #4.	0%	1%	8%	62%	28%	
3. My understanding of scientific uncertainty has improved as a result of Lab #4.	0%	4%	38%	44%	11%	
4. My ability to apply dimensional analysis to engineering problems has improved as a result of Lab #4.	0%	8%	6%	53%	32%	
5. My competency in the use of wind tunnels, multimeters, anemometers, and other measuring instruments has increased as a result of Lab #4.	0%	1%	7%	63%	28%	
6. I practiced teamwork, communication, and/or organizational skills during my completion of Lab #4 and its related assignments.	0%	2%	6%	47%	44%	
7. Lab #4 challenged my analytic and problem-solving skills.	1%	1%	13%	52%	31%	
8. I benefited from Lab #4's use of a tangible system (model wind turbine + wind tunnel) to demonstrate wind turbine theory.	0%	1%	7%	61%	30%	
9. UT Mechanical Engineering students benefit from project-oriented, industry-related curricula like Lab #4.	0%	1%	4%	39%	54%	
10. Lab #4 (Dimensional Analysis of a Scaled Down Wind Turbine) was a worthwhile class/assignment.	1%	0%	10%	53%	36%	

Fig. 12. Student assessments of Lab #4. There were 90 respondents to the survey. Responses may not add up to 100% due to rounding and unanswered questions.

of the fluid mechanics laboratory class (ME 130L). The survey consisted of ten statements about the lab, and students rated their level of agreement with each statement using the Likert scale. Comments were accepted for each question. Results are shown in Fig. 12, with a sample of comments shown in Fig. 13.

On average, feedback was 87% positive (35% Strongly Agree / 52% Agree), while only 2% of feedback was negative (0% Strongly Disagree / 2% Disagree). The first set of questions in the survey are oriented around what the students learned from performing the lab (1–5), while the second set of questions are oriented around students' satisfaction with the lab (6–10). In other words, students evaluated the lab via their individual development, then evaluated the lab directly.

Although response was generally positive, the surveys helped identify areas to target for improvement. Question 3, which asked students about their understanding of scientific uncertainty, had 42% selecting Neutral or Disagree. Question 4, on dimensional analysis, saw 14% mark Neutral, Disagree, or Strongly Disagree. These were two of the more difficult concepts in the lab, and the survey revealed that changes might be made to the proce-

dures or lab resources to guide students better through the uncertainty calculations and dimensional analysis. These results may also be indicative of the lack of exposure that students receive to these concepts before ME 130L; the foreignness of the ideas makes it more difficult for students to work through the material.

More specifically, dimensional analysis should be introduced in the lecture portion of the Fluid Mechanics curriculum before students are required to perform the lab. Students typically feel overburdened when asked to, at the same time, learn the material conceptually and apply it in a hands-on scenario. This would not be a difficult alteration, since dimensional analysis can stand alone (i.e. does not depend as heavily on previous lecture material as other concepts) and thus can be moved easily within the curriculum's chronology. Also, some effort could be made to make the lab exercises more similar to those covered in the lecture, thereby making the lab exercises less intimidating. This last would be best left to the prerogative of those implementing the lab/lecture, as too much similarity could undermine students' opportunity for problem solving.

-
- Especially the idea of cut-in and cut-out speeds and why this occurs
 - Already well educated in this area
 - Definitely. Just doing the uncertainty calculations as an exercise to see how much the uncertainty was compounded through the various steps in calculating the final numbers, was valuable. Painful, but valuable.
 - Tedious, but very instructive
 - It would help if what to do were more clear
 - It can be a lot to figure out and understand, while trying to get results in the period of time
 - it did teach me that I needed to take a more assertive role in leading and making sure that future team projects were completed correctly and on time.
 - I found it challenging.
 - Lab 4 was good but would be better if we were given reading supplements.
 - Excellent lab overall, would be very interesting if we could study effect of blade angle more closely, not sure how many students picked up the significance
 - Very much enjoyed this lab as well as all others. Work load was extremely high but favorite lab class thus far.
 - Realizing that the efficiency of a scaled down wind turbine were much lower than a regular sized wind turbine was quite disappointing, although I think the main idea of the importance of efficiencies in wind turbines in general came across well. If there is any way to increase the efficiency of a smaller wind turbine, I think students would see a more real-world application of the lab and wind turbines in general.
 - We did dimensional analysis in the lab before doing it in the main Fluids class. It was confusing and difficult without having the lecture to support our understanding of the subject. I'd recommend syncing up better with the main lecture for this particular topic.
 - No suggestions, overall educational and useful lab.
 - This was the most informative, useful, amazingly fun and applicable lab i have ever done in my scholastic history. I would like to have seen some more analysis points of the turbine and perhaps a little more scale to operation size comparisons and perhaps a different sized model with more appropriate blades. Also a second turbine type to compare. Like a Darrius or something. Otherwise this lab was awesome!!!!
 - I thought that the calculations were a bit excessive. Otherwise it was a good lab.
 - Lab 4 was a ridiculous amount of work though
 - It was hard to learn everything that was supposed to be taught during this lab because it was so long and time consuming and needed to be split up between group members.
 - Fun and challenging lab. Very rewarding to complete.
-

Fig. 13. Sample comments from student surveys. Comments were generally aligned with ratings shown in Fig. 12.

Improvement with respect to scientific uncertainty is more challenging, though, as the cause of difficulty is less clear. Of respondents, 38% chose Neutral, and 4% chose Disagree. The question's wording means that the Neutral selection could indicate that students were not challenged enough. In other words, their understanding did not improve because they already knew the material or they felt it was trivial and so no significant improvement took place. This hypothesis is supported somewhat by the quiz results presented above. Alternatively, students might simply be unsure about whether or not their understanding had improved because of their remaining confusion over the topic. Students could be challenged and tested for competency at the same time if they were required to perform unguided uncertainty calculations for the lab conducted after this one. As the calculations for this lab are guided, an unguided, foreign context would motivate students to seek assistance (those that needed it, from teachers, teaching assistants, or fellow students) or would at least reveal an acceptable level understanding.

Drawing conclusions from the written responses was just as important, as some of the most specific feedback was given there. A repeated complaint was that the efficiency of the scale model did not compare well enough with the full-scale turbine. Students would like to see a better match between the two in order to confirm their expectations of dimensional analysis. Although finding differences in the performance of the two can be just as instructive, it may be better to use a higher quality wind turbine (i.e. one with a higher power coefficient and that operates closer to the range of the full-scale HAWT).

In contrast with questions 3 and 4, 98% agreed with the statement that the lab increased their knowledge of wind turbine theory and practice. 90% agreed that their understanding of power, efficiency and losses had improved because of the lab. These were high priorities in the development of the lab, and survey results confirmed the effectiveness of the implementation.

More overarching questions met with very positive response. About 91% of students felt that they benefited from that tangible system used in the lab, and 93% thought that the Mechanical Engineering program was enhanced by the lab's project-oriented, industry-related curriculum. 89% felt that the lab was a worthwhile assignment. These results strongly support the tenants of PROCEED that guided the development of the lab.

7. Concluding remarks

The goal for this paper is to present a blueprint for using wind power technology to teach a variety of

concepts and terminology through analysis and evaluation via a project-centered approach. Through this project, students received exposure to the technical side of an increasingly important sector of the economy while, at the same time, they applied concepts learned in their classes (e.g. fluid dynamics, dimensional analysis and efficiency characterization).

Assessments indicated quantifiable improvement in all targeted content, with especially good results for wind turbine and fluid mechanics concepts. Surveys confirmed that the curriculum engaged students in a multifaceted way, with very positive feedback given for the project-based approach and the technical content. Identified areas of improvement include picking a wind turbine model that better matches the full-scale version to allow for more direct comparisons. Also, dimensional analysis needed more conceptual treatment and preparation before students applied it in the lab.

This experiment is considered a starting point from which other concepts can be taught. Once students know how to measure and characterize turbine performance, they can begin varying design parameters to improve or optimize the system. Changing the pitch angle is just one example. Other simple options for this include changing the generator's load, using different blade shapes (included with the model turbine presented here), or repositioning the turbine within the air stream. More complicated avenues for experimentation include making comparisons with computation fluid dynamics (CFD) predictions of performance or evaluations during dynamic load/wind conditions.

It is hoped that this experiment will help educators to enhance their engineering curriculum through connecting content to real-world applications through a project-oriented environment.

Acknowledgments—The authors would like to thank Dr. Phil Schmidt and PROCEED for supporting the development of this lab module; the project would have otherwise been impossible. Many others contributed, but special appreciation should be given to electronics shop technician Tho Huynh for his guidance and help with the fluids laboratory equipment. Graduate research assistants Brian Carroll, Onur Demirel and Andrew King also provided support, along with undergraduate research assistant Abigail Edwards.

References

1. U.S. Energy Information Administration: Renewable & alternative fuels: Wind, <http://www.eia.gov/cneaf/solar.renewables/page/wind/wind.html>, accessed 14 May 2012.
2. P. S. Schmidt and J. J. Beaman, PROCEED: A department-wide curriculum reform initiative in project-centered education, *Proceedings of the 2003 American Society for Engineering Education Annual Conference and Exhibition*, 13 January 2003, 13 January 2003, pp. 1–12.
3. American Wind Energy Association: Annual report, http://www.awea.org/newsroom/pressreleases/Annual_Report.cfm, accessed 14 May 2012.

4. A. Betz, *Introduction to the Theory of Flow Machines*, Pergamon Press, Oxford, 1966.
5. M. Ragheb and A. M. Ragheb, Wind turbines theory—The Betz equation and optimal rotor tip speed ratio, fundamental and advanced topics in wind power. In R. Cariveau (ed.), *Fundamental and Advanced Topics in Wind Power*, InTech, 2011.
6. A. J. Wortman, *Introduction to Wind Turbine Engineering*, Butterworth Publishers, Boston, 1983.
7. A. R. Hambley, *Electrical Engineering: Principles and Applications*, Pearson Education, New Jersey, 2011.
8. National instruments: Designing controllers for a doubly-fed wind power system, <http://zone.ni.com/devzone/cda/epd/plid/6272>, accessed 14 May 2012.
9. M. Ragheb, *Optimal Rotor Tip Speed Ratio*, <https://netfiles.uiuc.edu/mragheb/www/NPRE%20475%20Wind%20Power%20Systems/Optimal%20Rotor%20Tip%20Speed%20Ratio.pdf>, accessed 7 June 2012.
10. J. F. Manwell, J. G. McGowan and A. Rogers, *Wind Energy Explained: Theory, Design and Application*, John Wiley & Sons Ltd, Chichester, U.K., 2009.
11. M. Seward, *Electric Motors in Electrical Engineering*, Orange Apple, Delhi, 2012.
12. D. J. Burnham, J. C. Campbell, S. Santoso, A. Compean and J. Ramos, Developing wind power simulations and laboratory experiments for courses in renewable-energy systems, *American Society for Engineering Education*, 2009.
13. M. Chinchilla, S. Arnaltes and J. L. Rodríguez-Amenedo, Laboratory set-up for wind turbine emulation, *2004 IEEE International Conference on Industrial Technology (ICIT)*, 2004, pp. 553–557.
14. B. Bosma and G. Kallio, Renewable-energy labs for an undergraduate energy-systems course, *American Society for Engineering Education*, 2009.
15. S. D. Cogger and D. H. Miley, Model Wind turbine design in a project-based middle school engineering curriculum built on state frameworks, *Advances in Engineering Education*, 2012.
16. J. R. Taylor, *An Introduction to Error Analysis: The Study of Uncertainties in Physical Measurements, Second Edition*, University Science Books, Sausalito, CA, 1997.

Appendix

Wind turbine lab student performance evaluation quiz

ME 130L

Experimental Fluid Mechanics

Assessment Quiz Lab #3—Dimensional Analysis of a Scaled Down Wind Turbine

Please choose the best answer.

1. Wind turbines capture i energy from the wind and convert it into ii energy, which is then used to drive a generator that produces iii energy.

- A. i—mechanical, ii—electrical, iii—kinetic
- B. i—kinetic, ii—electrical, iii—mechanical
- C. i—mechanical, ii—kinetic, iii—electrical
- D. i—kinetic, ii—mechanical, iii—electrical

2. HAWT stands for

- A. High Altitude Wind Turbine
- B. Heat Assisted Wind Transfer
- C. Horizontal Axis Wind Turbine
- D. Hydro Axial Wind Turbine
- E. Hot-wire Anemometer Wind Tunnel

3. For a typical wind turbine, label the following points (i, ii and iii) in the plot of wind speed vs. wind turbine electrical power output:

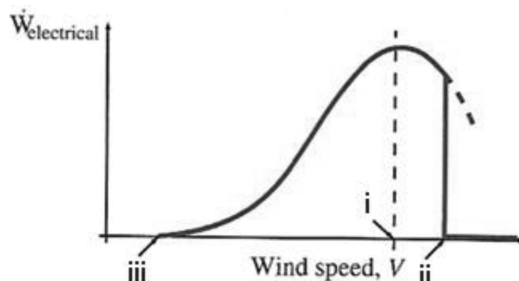

- A. i—Maximum power, ii—Top speed, iii—Low speed
- B. i—Rated speed, ii—Cut-out speed, iii—Cut-in speed
- C. i—Top speed, ii—Maximum power, iii—Rated speed
- D. i—Cut-in speed, ii—Cut-out speed, iii—Rated speed

4. The aerodynamic efficiency of a wind turbine (also known as the power coefficient), C_p , is the

- A. Ratio of the electrical power to the wind power (P_{elec}/P_{wind})
- B. Ratio of the mechanical power to the wind power (P_{rotor}/P_{wind})
- C. Ratio of the electrical power to the mechanical power (P_{elec}/P_{rotor})
- D. Ratio of the wind power to the mechanical power (P_{wind}/P_{rotor})
- E. Ratio of the mechanical power to the electrical power (P_{rotor}/P_{elec})

5. The wind power, P_{wind} , is proportional to the wind velocity, V_∞ , raised to the

- A. First power (V_∞)
- B. Second power (V_∞^2)
- C. Third power (V_∞^3)
- D. Fourth power (V_∞^4)

6. The i Limit describes a wind turbine's maximum theoretical ii , and its value is approximately iii .

- A. i—Reynolds, ii—overall efficiency, iii—0.45
- B. i—Nusselt, ii—aerodynamic efficiency, iii—0.56
- C. i—Betz, ii—electromechanical efficiency, iii—0.77
- D. i—Reynolds, ii—electromechanical efficiency, iii—0.63
- E. i—Betz, ii—aerodynamic efficiency, iii—0.59

7. The tip-speed ratio, λ , is described by the following equation, where:

ω the wind turbine rotational speed

R_{rotor} the radius of the wind turbine's rotor (for HAWTs)

V_∞ wind velocity, free stream

- A. $\lambda = \frac{\omega R_{rotor}}{V_\infty}$
- B. $\lambda = \frac{R_{rotor}}{\omega V_\infty}$
- C. $\lambda = \frac{\omega V_\infty}{R_{rotor}}$
- D. $\lambda = \omega V_\infty R_{rotor}$

8. Mark answers as

- A. True
- B. False

- a. The most efficient, ideal wind turbine would be able to capture all the energy in the wind.
- b. If all the energy in the wind were captured, the wind velocity would be reduced to zero.
- c. The faster a wind turbine spins, the more efficient it will be.
- d. Modern wind turbines change their blade angle and use mechanical brakes to control their speed.
- e. Larger wind turbines generally have better electromechanical efficiency.
- f. Lower blade pitch angles make turbines more aerodynamically efficient.
- g. Savonius turbines have the most efficient design.

9. The power coefficient, C_p , describes the aerodynamic efficiency of a wind turbine, and η_{em} is the electromechanical efficiency. The overall efficiency, $\eta_{overall}$ is then

- A. $C_p \eta_{em}$
- B. $C_p - \eta_{em}$
- C. $\eta_{em} - C_p$
- D. $\frac{C_p}{\eta_{em}}$
- E. $\frac{\eta_{em}}{C_p}$

10. Experimental uncertainty propagation refers to how

- A. Mistakes in lab procedure affect the final experimental results
- B. The error in one measured value affects the error in another measured value
- C. Limitations of instrumentation affect measured values
- D. Errors in measured values affect dependent, calculated values

11. For the following scenarios, select whether it is an example/description of

- A. Systematic error
- B. Random error

- a. Miscalibration of the vane anemometer results in velocity readings that are consistently 5 m/s greater than they should be.
- b. Ambient air temperature measurements in the lab vary with no apparent pattern from 70°F to 75°F.
- c. Data is precise but not accurate.
- d. Data is noisy.
- e. Differences in the measurements of one quantity that vary unpredictably.
- f. Differences between the measured value and the expected quantity that arise from a bias.

12. The uncertainty of a function $f(x)$ can be estimated with the following equation, where s_x is the uncertainty of x .

A. $\sqrt{\left(\frac{\partial f}{\partial x}\right)^2 s_x^2}$ B. $\sqrt{\left(\frac{\partial f}{\partial x}\right) s_x^2}$ C. $\sqrt{\left(\frac{\partial f}{\partial x}\right)^2 s_x}$ D. $\sqrt{\left(\frac{\partial f}{\partial x}\right) s_x}$

13. Dimensional analysis allows one to

- A. Compare similar phenomena at different scales
- B. Derive mathematical relationships using the units of the quantities of interest
- C. Check derived equations for consistency
- D. Use laboratory models to predict prototype behavior
- E. All of the above

14. Which of the following expressions represents a dimensionless parameter, where

$$\rho = \text{density} \left(\text{e.g. } \frac{\text{kg}}{\text{m}^3} \right) \qquad V = \text{fluid velocity} \left(\text{e.g. } \frac{\text{m}}{\text{s}} \right)$$

$$l = \text{characteristic length} \left(\text{e.g. } \text{m} \right) \qquad \mu = \text{fluid dynamic viscosity} \left(\text{e.g. } \frac{\text{kg}}{\text{m} \cdot \text{s}} \right)$$

$$u = \text{fluid kinematic viscosity} \left(\text{e.g. } \frac{\text{m}^2}{\text{s}} \right)$$

A. $\frac{\rho V l}{\mu}$ B. $\frac{\rho V l}{v}$ C. $\frac{\rho V}{v}$ D. $\frac{\rho \mu l}{v}$

15. The Buckingham Pi Theorem states, simply, that an equation involving k variables and r unique dimensions/units can be reduced to a relationship among independent, dimensionless products.

A. $k + r$ B. $r - k$ C. $k - r$ D. kr E. $\frac{k}{r}$

Everett Sheble is a graduate of the baccalaureate Mechanical Engineering program at the University of Texas at Austin and a research assistant to Dr. C. Hidrovo. He currently works as an Energy Analyst at the energy efficiency consulting firm CLEARResult, headquartered in Austin. His interests include renewable energy and sustainability and engineering education.

Steffen Bickle is a graduate student at The University of Texas at Austin. He earned his Diplom-Ingenieur degree in Mechanical Engineering from the Karlsruhe Institute of Technology in 2010. He works as a research assistant in the Combustion Engine group in the Department of Mechanical Engineering of The University of Texas at Austin under the supervision of Prof. Ron D. Matthews. Since 2012 he has also worked with the Advanced Combustion and Emissions group at the Southwest Research Institute (SwRI), San Antonio. His dissertation topic within the High Efficiency Dilute Gasoline Engine (HEDGE) project focuses on the potentials and challenges of new combustion modes in combination with advanced internal combustion engine technology in highly downsized engines. Previously, he was a teaching assistant for the Experimental Fluid Mechanics Laboratory.

Carlos H. Hidrovo is an assistant professor of Mechanical Engineering at The University of Texas at Austin. He earned his Ph.D. in Mechanical Engineering from the Massachusetts Institute of Technology in 2001. Dr. Hidrovo worked as a Research Scientist in the 3D Optical Systems group at MIT and as a Research Associate in the Micro Heat Transfer Laboratory at Stanford University before joining the faculty of The University of Texas at Austin in September 2007. He is the recipient of a 2012 NSF CAREER Award from the Fluid Dynamics program, the 2008 DARPA Young Faculty Award, and the American Society of Mechanical Engineering 2001 Robert T. Knapp Award. Dr. Hidrovo's research interests lie at the intersection of multiscale and multiphase flow and transport phenomena, surface tension interactions in micro/nanoengineered structures, and electrokinetic ion transport in porous media for applications in energy storage, portable biochemical diagnostics, thermal management and water treatment systems. He is also actively involved in developing novel imaging and diagnostic tools in these areas. His pedagogical activities mainly revolve around teaching and developing new content for the undergraduate theoretical and experimental fluid mechanics courses, and for a graduate level course of his own on microscale flow and transport phenomena.